

# Duct Sealing and Testing

2018 VRC/VECC Inspection Guide



## Duct Testing and Sealing:

**Summary:** Virginia began requiring duct air-tightness to be measured with the 2015 code cycle, with a maximum leakage rate of 4%. This guide is intended to give both code and real world examples of what that change means for code enforcement in the Commonwealth.

**Why:** Consistent enforcement of the 2018 duct leakage provisions within the code will save the occupants of the more than 20,000 new homes built each year a combined \$1.24 million on an annual basis. (Figure 1).<sup>1</sup> According to the Building America Solutions Center, “Duct leakage is a double hit on the utility bill: 1) duct leaks are an uncontrolled loss of conditioned air to the outdoors and 2) duct leakage drives building infiltration. For example, if a home had a 2.5-ton (30,000 BTU/H) cooling system moving 1,000 CFM (cubic feet per minute) of air and the ducts had 10% leakage (which is typical in code-built homes), the leakage rate would be 100 CFM. Each cubic foot of air carries with it 30 BTUs/H, so 3,000 BTUs of conditioned air would be lost to the outdoors each hour.”<sup>2</sup> In addition to monetary and energy concerns, uncontrolled infiltration can have significant effects on health and durability.

| Measure      | Total Energy Savings (MMBtu) | Total Energy Cost Savings (\$) | Total State Emissions Reduction (MT CO <sub>2</sub> e) |
|--------------|------------------------------|--------------------------------|--|
| Duct Leakage | 6,4168                       | 1,244,243                      | 31,520   |

Figure 1: Estimated Annual Statewide Savings Potential

If any component of an HVAC System is located outside of the building’s thermal envelope, the system will be required to be pressure tested to determine air leakage. This test can take place at rough-in or after HVAC trim out has been completed. VECC R403.3.4 provides standards for leakage based on what components are installed during the time of the test:

- 3 Cubic Feet per Minute (CFM) / 100 Sq. Ft. of Floor Area Served (or 3% of CFA at rough-in without the air handler installed)
- 4 Cubic Feet per Minute (CFM) / 100 Sq. Ft. of Floor Area Served (or 4% of CFA at rough-in with the air handler installed or at final)

$$\text{Duct Leakage} = \frac{\text{cfm}_{25}}{\text{square ft. of floor area served (CFA)}}$$

<sup>1</sup> [https://www.energycodes.gov/sites/default/files/documents/Virginia\\_Residential\\_Field\\_Study.pdf](https://www.energycodes.gov/sites/default/files/documents/Virginia_Residential_Field_Study.pdf)

<sup>2</sup> <https://basc.pnnl.gov/resource-guides/sealed-and-insulated-flex-ducts#edit-group-description>

Virginia code (R403.3.3) allows anyone that has been trained on the duct testing equipment to provide duct leakage measurements.

**Meeting N1103.3.3 (R403.3.3):**

1. Determine location of HVAC systems within the home. If all ducts and associated air handlers are 100% within the building envelope, duct testing is not required. Spaces within the building envelope include conditioned crawl spaces, conditioned attics, and the space between conditioned floors. If there are multiple systems and some are completely within the building envelope and some are not, only the system(s) not fully within the building envelope are required to be tested.
2. If duct testing is required, determine the duct leakage target. The square feet served by each system must be determined in order to understand necessary duct leakage targets.
  - a. *Example:* 1 system serving the entire home. Conditioned floor area of the home is 1,200 sq. ft.

$$4\% \text{ of conditioned floor area} = 1,200 \times 0.04 = 48$$

To pass final duct leakage at final inspection: **CFM<sub>25</sub> must be ≤ 48 CFM**

A written report of the results of the test shall be signed by the party conducting the test and provided to the code official. Check to ensure all systems are at or below required duct leakage based on floor area served.

**Notes:**

- \* *Duct boot to drywall and duct boot to subfloor connections are typically the largest offenders for total leakage, including returns boot connections to drywall*
- \* *Duct boots can be easily covered by drywall and lead to higher leakage in the field*
- \* *Ventilation systems connected to the central heating and cooling system can also increase leakage if not operating properly*
- \* *Based on the [Virginia Residential Energy Code Field Study](#) results, 94% of systems tested in the participating homes in 2017 and 2018 were over the 4 cfm/100 sq ft threshold, with that dropping to an 84% failure rate with the conditioned space exemption applied*
- \* *Duct leakage drives infiltration, or air leakage, through the envelope; it can negatively or positively pressurize the house depending on where the ducts are leaking, pulling outside air in through cracks in the building envelope or pushing conditioned air out. If the duct leakage is in the supply-side ducts, the house will be negatively pressurized compared to outdoors. If all the leakage is on the return side, the building will be positive with respect to outdoors<sup>3</sup>*

---

<sup>3</sup> <https://basc.pnnl.gov/resource-guides/sealed-and-insulated-flex-ducts#edit-group-description>

### Duct Sealing Visuals:

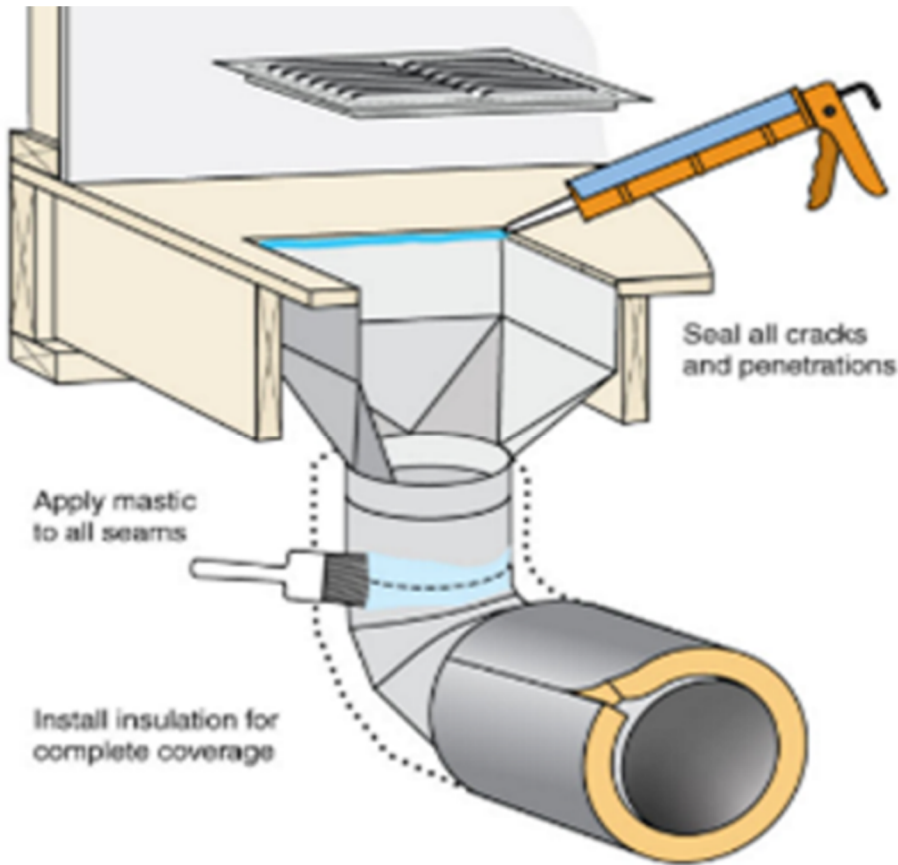

Figure 1: Joints and seams at duct boot sealed



Figure 2: Increased duct and envelope leakage if left unsealed

### Air Handler to Plenum

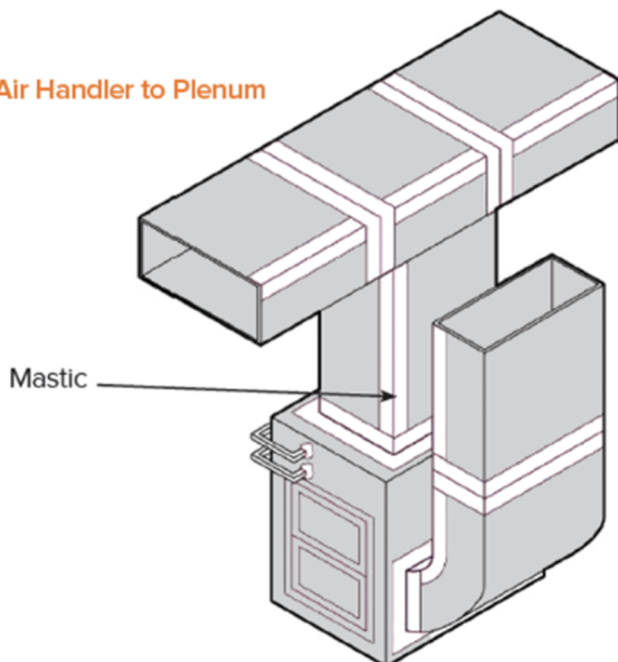

Figure 3: Well sealed plenum and trunk



Figure 4: Well sealed supply-to-trunk connection



Figure 5: Unsealed tabular duct takeoff



Figure 6: Unsealed and poorly supported duct takeoff



Figure 7: Mastic paste used as permanent seal – “thick as a nickel”

## Duct Testing Code References:

**Section R403.3.3/N1103.3.3 Duct testing (Mandatory).** Ducts shall be pressure tested to determine air leakage by one of the following methods:

1. **Rough-in test.** Total leakage shall be measured with a pressure differential of 0.1 inch water gage (25 Pa) across the system, including the manufacturer's air handler enclosure if installed at the time of the test. All registers shall be taped or otherwise sealed during the test.
2. **Post-construction test.** Total leakage shall be measured with a pressure differential of 0.1 inch water gage (25 Pa) across the entire system, including the manufacturer's air handler enclosure. Registers shall be taped or otherwise sealed during the test.

**Exception:** A duct air leakage test shall not be required where the ducts and air handlers are located entirely within the *building thermal envelope*.

A written report of the results of the test shall be signed by the party conducting the test and provided to the code official. The licensed mechanical contractor installing the mechanical system shall be permitted to perform the duct testing. The contractor shall have been trained on the equipment used to perform the test.

**Section R403.3.4/N1103.3.4 Duct Leakage (Prescriptive).** The total leakage of the ducts, measured in accordance with Section R403.3.3/N1103.3.3, shall be as follows:

1. **Rough-in test.** The total leakage shall be less than or equal to 4 cubic feet per minute (113.3 L/min) per 100 square feet (9.29 m<sup>2</sup>) of conditioned floor area where the air handler is installed at the time of the test. Where the air handler is not installed at the time of the test, the total leakage shall be less than or equal to 3 cubic feet per minute (85 L/min) per 100 square feet (9.29 m<sup>2</sup>) of conditioned floor area.
2. **Post-Construction test.** Total leakage shall be less than or equal to 4 cubic feet per minute (113.3 L/min) per 100 square feet (9.29 m<sup>2</sup>) of conditioned floor area.

## Duct Sealing Code Reference:

**Section R403.3.2/N1103.3.2 Sealing (Mandatory).** Ducts, air handlers, and filter boxes shall be sealed. Joints and seams shall comply with Section M1601.4.1.

**N1103.3.2.1 (R403.3.2.1) Sealed air handler.** Air handlers shall have a manufacturer's designation for an air leakage of not greater than 2 percent of the design airflow rate when tested in accordance with ASHRAE 193.

## Duct Location Code Reference:

**Section R403.3.5/N1103.3.5 Building Cavities (mandatory).** Building framing cavities should not be used as ducts or plenums.

## Definitions:

**Building Thermal Envelope:** The basement walls, exterior walls, floor, roof, and any other building elements that enclose conditioned space or provide a boundary between conditioned space and exempt or unconditioned space

**Conditioned Space:** An area, room, or space that is enclosed within the building thermal envelope and that is directly heated or cooled or indirectly heated or cooled

**Above-Grade Wall:** A wall more than 50% above grade and enclosing conditioned space. This includes between-floor spandrels, peripheral edges of floors, roof and basement knee-walls, dormer walls, gable end walls, walls enclosing mansard roof, and skylight shafts

**Air Barrier:** One or more materials joined together in a continuous manner to restrict or prevent the passage of air through the building thermal envelope and its assemblies

**R-Value:** The inverse of the time rate of heat flow through a body from one of its bounding surfaces to the other surface for a unit temperature difference between the two surfaces, under steady state conditions, per unit area ( $h \cdot \text{ft}^2 \cdot ^\circ\text{F}/\text{Btu}$ ) [ $(\text{m}^2 \cdot \text{K})/\text{W}$ ]. *\*Note: In more general terms, resistance to heat flow of a single material, expressed as a whole number. Higher numbers denote higher resistance to heat flow*

**U-Factor (U-Value):** The coefficient of heat transmission (air to air) through a building component or assembly, equal to the time rate of heat flow per unit area and unit temperature difference between the warm side and cold side air films ( $\text{Btu}/\text{h} \cdot \text{ft}^2 \cdot ^\circ\text{F}$ ) [ $\text{W}/(\text{m}^2 \cdot \text{K})$ ]. *\*Note: In more general terms, resistance to heat flow of multiple materials expressed as a decimal point. Lower numbers denote higher resistance to heat flow*

**Infiltration:** The uncontrolled inward air leakage into a building caused by the pressure effects of wind, or the effect of differences in the indoor and outdoor air density or both